

SP-240

The screenshot displays the SP-240 SmartPanel interface. At the top, it shows 'Produktion' with a date of '03.09.2002' and a time of '15:39:41'. Below this, the 'Rezeptname MyTyp1' is 'Produkt XY'. The 'Takte/min.: 72' and 'Produkte/min.: 9.0' are displayed. A central diagram shows a production line with three workstations. At the bottom, a green bar indicates 'Maschine läuft'. To the right of the main interface are four logos: EPAM™, CoDeSys, CANopen, and Microsoft Windows CE.

Copyright

Keep documentation for future use!

This documentation is the intellectual property of **Grossenbacher Systeme AG**, which also has the exclusive copyright. Any modification of the content, duplication or reprinting of this documentation, as well as any distribution to third parties can only be made with the express permission of **Grossenbacher Systeme AG**.

Grossenbacher Systeme AG does not accept any liability for damages arising from the use of any incorrect or incomplete information contained in this documentation or any information missing therefrom.

Grossenbacher Systeme AG reserves the right to make complete or partial modifications to this document.

All brand and product names are trademarks or registered trademarks of the owner concerned

Proper use

The device must only be used for the applications specified in the device description and only in conjunction with the components recommended by Moeller GmbH.

Warning

Trouble-free and safe operation of the product can only be ensured if the measures relating to proper transport, storage, assembly, installation and careful operation are strictly observed.

The device must not be switched on when it is covered with condensation. When changing its location from cold to warm allow the device to acclimatize to the new conditions before commissioning.

No warranty claims will be recognized for faults arising from the improper handling of the device.

The device should not be used for the implementation of any safety functions relating to the protection of personnel and machinery.

No liability is accepted for claims for damages arising from a failure or functional defect in the device.

All data specified in this document does not represent guaranteed specifications in the legal sense.

Safety instructions for the user

This device description contains the information required for the proper use of the products described therein. Sections 1 to 10 address technically qualified personnel and Section onwards addresses personnel not requiring any technical knowledge.

Qualified personnel in the sense of the safety instructions given in this device description or on the product itself are persons who:

as engineering personnel are either familiar with the safety concepts of automation,

or as operating personnel, are instructed in the use of automation components and are familiar with the contents of this device description relating to the operation of the device,

or as commissioning or service personnel are suitably trained for the repair of automation devices and are authorized to commission circuits and devices/systems in accordance with standard safety engineering principles.

Contents

1	Explanation of symbols	7
2	Introduction	9
3	Device Versions	11
3.1	Specification	11
3.2	Accessories	12
4	Features	13
5	Commissioning	15
5.1	Overview of connections	15
5.2	Connecting the power supply	15
5.3	Power Fail and UPS	16
5.4	Fuse	16
5.5	Setup of RTC	16
5.6	Preparing the shield connections	17
5.7	Connecting the Ethernet	18
5.8	Connecting the USB-Interface	18
5.9	Connection for COM1 serial interface	19
5.10	CAN interface	19
5.11	Inserting / Removing the Micro-SDCARD™	22
5.12	Temperature sensor connector	22
6	Operation	23
6.1	Startup / Shutdown behaviour	23
7	Mounting instructions	23
7.1	General mounting instructions	23
7.2	Mounting in the front panel - General	23
7.3	Front panel cutout 3,5" to 7"	24
7.4	Mechanical dimensions - Frontside 3,5" to 7"	25
8	Notes on the touch-screen	29
8.1	Basic touch-screen function	29
9	Backlight, contrast	31
9.1	Contrast	31
9.2	Backlight	31
9.3	Diagnostics	31
10	Maintenance and repair	33
11	Technical data	35
12	Disposal	37
13	EU Conformity and Standards	39
14	Revision history	41
15	Alphabetical index	43

1 Explanation of symbols

Danger warnings

The following information is for your personal safety and the prevention of damage to the device described or connected devices.

Safety instructions and warnings for the prevention of danger to the life and health of users or service personnel, and for the prevention of damage are highlighted in this document by the following pictograms. “Warning” and “Information” pictograms are shown in this document.

Warnings indicate the following:

Death, serious injury or substantial material damage may occur if the related safety measures are not implemented.

The individual “Warning” pictograms have the following meaning:



Caution! General!

An instruction to be observed in order to ensure protection against hazards and the safe operation of the device. The specified procedure should be observed.



Caution! Electric shock!

Persons may be exposed to dangerous voltages that occur in electrical systems. There is a danger of electric shock if a live part is touched.



Caution! Observe ESD measures!

Electrostatic discharge may destroy electronic components.

Information pictograms indicate the following:

Important information about the product or the relevant section of the document, requiring the particular attention of the reader.

The “Information” pictogram has the following meaning:

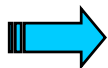

Indicates important and instructional information.

2 Introduction

The new SmartPanels enhances the openAutomation concept of Grossenbacher System AG in the range of small and medium applications. So price and performance can be optimized to the requirements of the application.

Based on a powerful 400MHz ARM processor with WindowsCE or Linux, 3,5", 4,3", 5,7" or 7" TFT display with LED backlight and touch screen, Ethernet, USB-Host and CAN on-board, the devices perfectly fits together with the openAutomation software solutions of Grossenbacher Systeme AG.

In the basic configuration the device can be used as „HMI“ or as a user programmable „HMI-Open“ with Ethernet, USB and CAN onboard.

With CoDeSys IEC-61131 Soft-PLC the device can be used as "HMI-Control" with Codesys including integrated TargetVisu and WebVisu.

Without moving parts the devices are "at home" in rugged environment!

The seamless resistive touch-screen provides a fast, intuitive and ergonomic operation.

Unique is the mechanical concept with one equal mounting cutout for all devices! So it is possible to change the display size at any time very easy without mechanical changes!

Features:

- 3,5", 4,3", 5,7" or 7" TFT
- One mounting cutout for all sizes
- Resistive Touch-screen
- Powerful 400MHz ARM CPU
- WindowsCE or Linux
- Fanless
- Ethernet
- Exchangeable micro SD-Card
- CANopen
- CoDeSys Soft-PLC (Option)

The devices can be installed in control panels or control desks without any problem. The devices are not designed for mobile use.

This device description is a reference for the technical data, installation, terminals, commissioning, operation, and maintenance of all SmartPanel versions.

Additional documentation:

System description WindowsCE	DVS 49631
System description CoDeSys Soft-PLC	DVS 49634

3 Device Versions

In this chapter all device versions of the SmartPanels and available accessories are specified.

3.1 SPECIFICATION

General features of all device versions:

Processor: 400MHz ARM CPU
 Memory: 64MB
 Mass storage: 128MB onboard NAND-Flash, MicroSD-Slot
 Interfaces: 1 x Ethernet
 2 x USB Master
 1 x RS232/485/422
 1 x CAN
 Stromversorgung: 24VDC

SP-240-03R-000	Ord.No.: 50 81 862 SmartPanel 3,5" TFT 320x240 64k colours Resistive-Touchscreen
SP-240-04R-000	Ord.No.: 50 81 863 SmartPanel 4,3" TFT 480x272 64k colours Resistive-Touchscreen
SP-240-05R-000	Ord.No.: 50 81 864 SmartPanel 5,7" TFT 640x480 64k colours Resistive-Touchscreen
SP-240-07R-000	Ord.No.: 50 81 865 SmartPanel 7" TFT 800x480 64k colours Resistive-Touchscreen

3.2 ACCESSORIES

<p>Runtime-System</p>	<p>Ord.No: 5055014 RTS HMI CEARM SPi25 WindowsCE6 Professional and EPAM-RTS preinstalled on Onboard Flash</p> <p>Ord.No: 5055015 RTS HMI-Control CEARM SPi25 3S WindowsCE6 Professional, EPAM-RTS and Codesys-RTS V2.3 preinstalled on Onboard Flash</p> <p>Ord.No: 5055030 RTS HMI ThinClient SPi25 WindowsCE6 Professional ThinClient preinstalled on Onboard Flash</p> <p>Ord.No: 5055033 RTS HMI-open .NET SPi25 WindowsCE6 Professional, .NET Framework preinstalled on Onboard Flash</p>
<p>Micro-SDCARD</p>	<p>Ord.No: 32 01 381 Micro-SDCARD 1GB, INDUSTRIAL</p> <p>Ord.No: 32 01 382 Micro-SDCARD 2GB, INDUSTRIAL</p>
<p>Stecker für Stromversorgung</p>	<p>Ord.No: 12 17 013 3pol Phoenix Contact, MSTB2.5/3-STF-5.08</p>

4 Features

Feature			Comment
Display	Display	Size	3,5"/4,3"/5,7"/7"
	Type	TFT	64k Colours (16Bit)
Touch-screen	Resistive touch-screen	Resolution	12 Bit (0-4096)
Realtime clock		Yes	Capacitor-backed (ca. 1 week)
Processor		Type	ARM9 iMX25
		Clock	400MHz
Mass storage	Onboard Flash	Type	128MB NAND Flash
Memory	SDRAM	MB	64MB
Retain memory		kB	256kB ¹
Exchangeable memory	Micro-SDCARD Memorystick	Type	Micro SD-Card-Slot or Memorystick (optional via USB)
Interfaces	COM1	Type	RS232/485/422, max. 115 kBit/s
	Ethernet 1	Type	10 / 100 MBit/s
	USB 1-2 (2.0)	Type	1.5 / 12 / 480 MBit/s
	Keyboard	Type	Optional via USB
	Mouse	Type	Optional via USB
	CAN	Type	CiA V2.0 Part B; max. 1 MBaud; not isolated
Power supply		Type	8,5VDC to 30VDC, NOT isolated

¹ Retain data will be saved on power fail to Flash

5 Commissioning

5.1 OVERVIEW OF CONNECTIONS

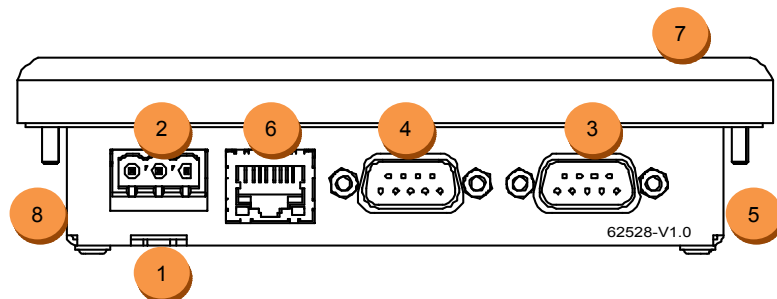

No.	Element	Description
1	Function earth	
2	24VDC power supply	➔ Chap. 5.2
3	COM1	➔ Chap. 5.9
4	CAN	➔ Chap. 5.10
5	2xUSB	➔ Chap. 5.8
6	1xEthernet	➔ Chap. 5.7
7	Micro-SDCARD-Slot	➔ Chap. 5.11
8	Temp.sensor connector	➔ Chap. 5.12

5.2 CONNECTING THE POWER SUPPLY

The SmartPanel devices belongs to protection class 3. The system power supply must be provided with a 24VDC **SELV** voltage (➔ Section 11). The power supply is NOT isolated. The GND connection is directly connected to the housing potential. The device is protected with a fuse (note disconnection capacity ➔ Section 11). A reverse polarity protective device is used to protect the device in the event of reversed poles. Operation, however, is only possible if the connection was made correctly. Connections for the SmartPanel must comply with specific, local regulations.

SmartPanel

Hardware

The connection must be made as follows:

1. The cross-section of the power supply cable must be at least 0.75 mm² and a maximum of 2.5 mm².
2. A flexible lead or wire can be used for the connection.
3. The current consumption (➔ Section 11) must be taken into account when implementing the power supply.
4. The functional earth is not compulsory for operation. But it can help to avoid disturbance caused by potential differences.
5. The GND connection is directly connected to the housing potential
6. For safety reasons the wires should be fixed together near by the connector

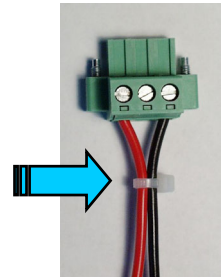

The plug connector (socket connector with screw terminals) is supplied with the device for connection.

Connector assignment

Designation	Function
+24 VDC	+24VDC power supply
	reserved
0 V	0V power supply

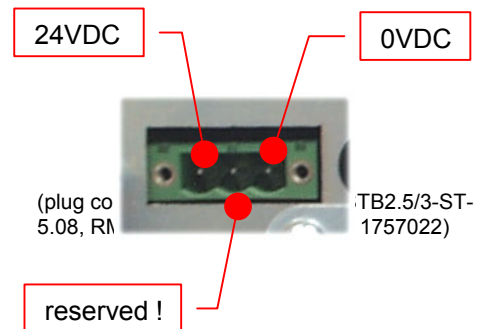

In the event of reverse connection and simultaneous connection of a further 0V connection, e.g. GND connection of the COM1 interface, the fault current flows via this 0V connection. If the housing is not lying well set on the 0V potential, the result can be destruction of the device or of the external components!



For safety reasons the wires should be fixed together near by the connector.

5.3 POWER FAIL AND UPS

The device includes a power fail functionality. The power fail mechanism prevents the loss of retain data if a Soft-PLC is used. The retain data are stored on Flash when the PLC is shutting down and are read out again when the PLC starts up. (for details s.a. System description Soft-PLC)

The standard integrated UPS-solution can bridge brownouts up to 5s.

5.4 FUSE

The device is protected with a fuse internally. The fuse can not be changed by the user.

5.5 SETUP OF RTC

If the device is powerless for a long time (more than 1 week), it may be necessary to setup the Time and Date again.

5.6 PREPARING THE SHIELD CONNECTIONS

The preparation of the data and signal cables is an important factor for the electromagnetic compatibility (EMC) of the SmartPanel, both in terms of interference immunity and emission.

The **RS232** and **CAN** interface are connected via D-Subminiature plug connectors in accordance with DIN 41652. Only use metal or metallised connector casings with a cable clamp for strain relief fastened or clamped on the connector. The clamping of the cable shield ensures an optimum contact area and a low impedance connection with the connector casing of the SmartPanel.

The following procedure is recommended for making the low-impedance connection for the cable shield:

1. Strip the cable.
2. Shorten the exposed shield braid by approx. 3 cm.
3. Turn back the braid over the cable sheath.
4. Use a heat shrinkable tubing or rubber grommet to cover the exposed cable sheath with the folded back shield braid so that 5 to 8 mm of exposed cable shield is left at the sheath end and is cleanly covered at the back.
5. Fit the connector
6. The cable is then fastened at the exposed shield braid and the cable sheath below it directly underneath the cable clamp strap of the connector casing.

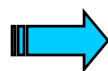
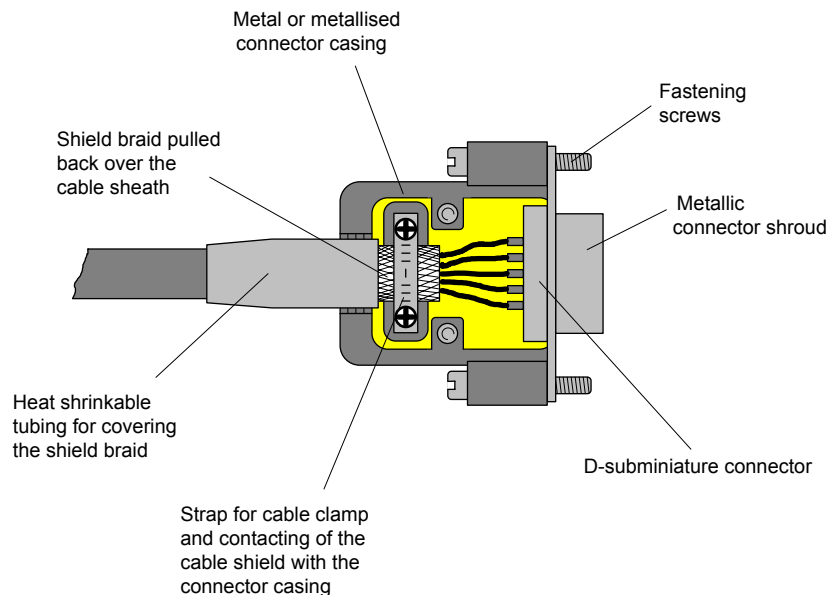

Connection work should be carried out with special care in order to ensure trouble-free operation. The EMC values stated in the technical data can only be guaranteed if the cables are prepared according to the following specifications.

SmartPanel

Hardware

5.7 CONNECTING THE ETHERNET

The Ethernet-Interface is compatible with standard IEEE 802.3 (10/100BASE-T).

The network connection is implemented via a Cat 5e cable with shield and RJ45 connectors. The maximum cable length and transfer speed is limited by the cable quality in EIA/TIA 568 TSB-36. Cable lengths up to 100m are possible.

Two diagnosis LEDs are available:

Orange: LINK (connection to HUB or to another device)
 Green: ACT (sending or receiving)

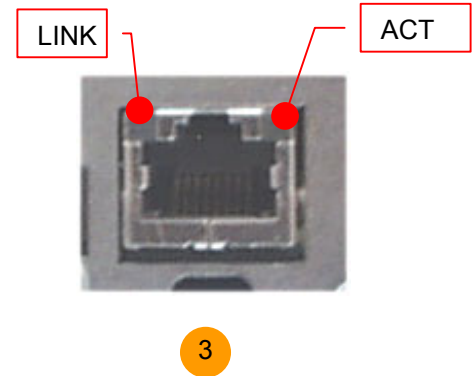

Cables connected to the Ethernet must be laid separately from the low-voltage cables.



To ensure disturbance-free operation, it is strongly recommended to use network cables with shield.

Connector assignment

**RJ45
connector**

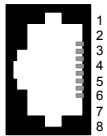

Socket, 8pole
RJ45

Pin No.	Signal	Description
1	TXD+	
2	TXD-	
3	RXD+	
4	-	
5	-	
6	RXD-	
7	-	
8	-	

5.8 CONNECTING THE USB-INTERFACE

The USB Interface is compatible to USB-standard Version 2.0

The use of the USB-Interface requires support by the operating system.

Cables connected to the USB must be laid separately from the low-voltage cables.

5.9 CONNECTION FOR COM1 SERIAL INTERFACE

The serial Interface COM1 is PC-compatible. This interface is not isolated. The GND connection is implemented directly on the housing potential (→ Section 11).

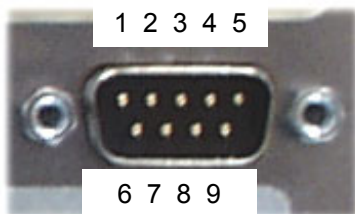

5

Connector

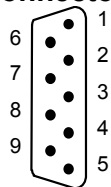

Connector
9pole
SubD

Pin No.	Signal	Description
1	-	n.c.
2	RXD	RS232
3	TXD/TXB(+)/485-B(+)	RS232/ 485/ 422
4	TXA(-)/485-A(-)	RS422/ 485
5	GND	direct on housing potential
6	-	n.c.
7	RTS	
8	CTS/RXA(-)	RS232/422
9	RXB(+)	RS422

Cables connected to the serial COM interface must be laid separately from the low-voltage cables.



To ensure disturbance-free operation, it is strongly recommended to use cables with shield.

The COM1 interface can be configured as RS232/485 or 422. In case of RS485 the configuration for send or receive is done automatically.

Dip-Switch:

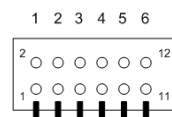

	232	422	485
1	on	off	off
2	on	off	off
3	off	on	on
4	off	on	on
5	off	off	on
6	off	off	on

5.10 CAN INTERFACE

The communication interface is defined in accordance with the CiA CAN Specification V2.0 part B. The fully-integrated CAN unit supports the sending and receiving of frames with an 11-bit identifier. The type of configuration selected depends on the software protocol. The baud rate can be selected in a wide range, and only the standard CiA baud rates are implemented.

SmartPanel Hardware

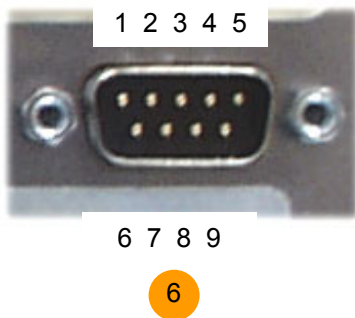

CAN connector			
Sub-D 9 Pole male			
Connector	Pin No.	Assignment	Function
	1	-	
	2	CAN LOW	Negative data signal
	3	GND	Signal Ground (ground potential)
	4	-	
	5	-	
	6	GND	Signal Ground (ground potential)
	7	CAN HIGH	Positive data signal
	8	-	
	9	CAN_V+	Internally connected with +24VDC; optional power supply via CAN-cable
	Case	Case	Cable shield

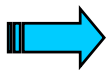

The CAN interface is **NOT** isolated.
The max. baud rate is 1MBit/s.

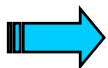

The terminating resistor must be implemented externally, e.g. in the connector, and is not part of the device.

Pin 9 (CAN-V+) is connected with +24VDC internally to provide optional power supply of the device via the CAN-cable.

A detailed description of the wiring is provided in the "Codesys Soft-PLC" system description

Wiring instructions

The stations on the bus system are connected via fieldbus lines complying with ISO 11898. The cables must accordingly have the following electrical characteristics:

Parameter	Abbreviation	Unit	Value min.	Value nom.	Value max.	Note
Impedance	Z	Ω	108	120	132	Measured between two signal lines
Specific resistance		m Ω /m		70		For the receiver module, the differential voltage on the bus cable depends on cable resistance between it and the sender
Cable delay		ns/m		5		The minimum delay between to points on the bus is 0. The maximum delay is determined by the bit timing and the delays of the sender and receiver circuits

The figure shows the minimum wiring with shielding between two bus stations with the Sub-D connector as an example. A bus terminating

resistor (120 Ohm between Pin 2 and Pin 7 of the Sub-D connector) must be connected at the beginning and the end of each CAN bus. Do not swap around the two signal wires!

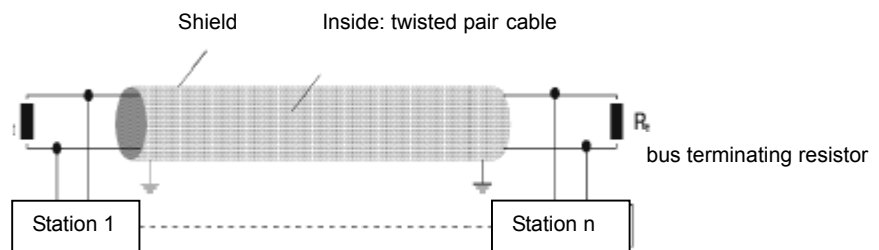
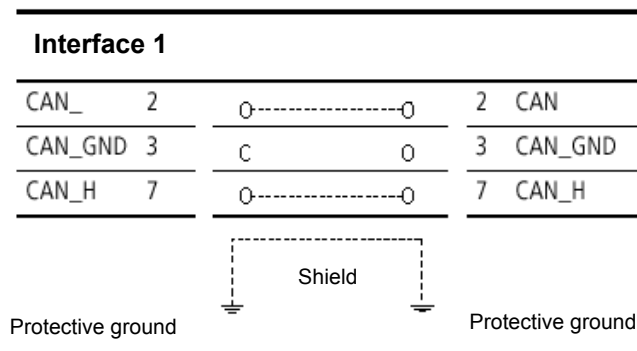

Pin 3 and 6 (CAN_GND) are both connected internally with the CAN Ground. Pins 4, 5 and 8 must *not* be connected! The CAN bus driver is fed internally.

Baud rate and cable lengths

Baud rate	Max. length
20kBit/sec	2500m
25kBit/sec	2000m
50kBit/sec	1000m
100kBit/sec	650m
125kBit/sec	500m
250kBit/sec	250m
500kBit/sec	100m
1Mbit/sec	6m

5.11 INSERTING / REMOVING THE MICRO-SDCARD™

The SmartPanel series devices use a Micor-SDCARD slot for removable mass storage devices.(s.a. accessories)

Micro-SDCARDS may be removed during operation. To avoid data loss it is recommended to use the operating system functionality to replace the removeable devices. (s.a. system description WindowsCE)

5.12 TEMPERATURE SENSOR CONNECTOR

The Temperature sensor connector can be used to connect a KTY10-6 (= KTY81-210) sensor to measure e.g. the room temperature.

6 Operation

6.1 STARTUP / SHUTDOWN BEHAVIOUR

After power on the SmartPanel boots the installed operating system from the Onboard-Flash.

7 Mounting instructions

7.1 GENERAL MOUNTING INSTRUCTIONS

All SmartPanel series devices are mounted from the front, i.e. in a control panel. They are fastened from the rear with the supplied 4 securing nuts.

All SmartPanel series devices can be operated up to a maximum ambient temperature of 60°C (→ Section 11). The ambient temperature stated applies to the area 5cm above the device, if it is mounted vertically with unimpeded air convection and a maximum operating height of 2000m above sea level.

The device can be mounted in an enclosure if the ambient temperature is taken into consideration. Provide a wall clearance of at least 50 mm on all sides of the housing, so that sufficient air circulation is ensured. A minimum clearance of 75 mm from active elements such as load current supply, transformers etc. must be ensured.

Avoid the exposure of the flat screen to direct sunlight. The radiation from the sun (UV component) reduces the lifespan of the LCD display.

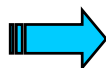

The following must be ensured in order to prevent the device from overheating during operation:

- **The cooling slots must always be free in order to ensure the proper cooling of the system.**
- **Avoid the exposure of the flat screen to direct sunlight.**
- **The mounting angle must not exceed $\pm 35^\circ$ from the vertical**

If these conditions cannot be met, the mounting of an external fan is recommended.

7.2 MOUNTING IN THE FRONT PANEL - GENERAL

1. The front seal must be inlaid from the back side. The seal is self-adhesive on one side.
2. Push the SmartPanel from the front into the cutout of the front panel.
3. Secure the device from the rear with the supplied 4 securing nuts which should be tightened evenly from the rear until the front frame is flush with the front panel all round.

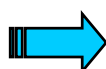

Ensure that the seal is fitted correctly on the front panel. Avoid tightening torques of greater than 0.5 Nm as this could otherwise damage the device.

The thickness of the front panel must not exceed 2.5 mm.

7.3 FRONT PANEL CUTOUT 3,5" TO 7"

Tolerance for panel cutout $+0/-0.5$ mm

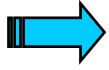

The thickness of the front panel must not exceed 2.5 mm.

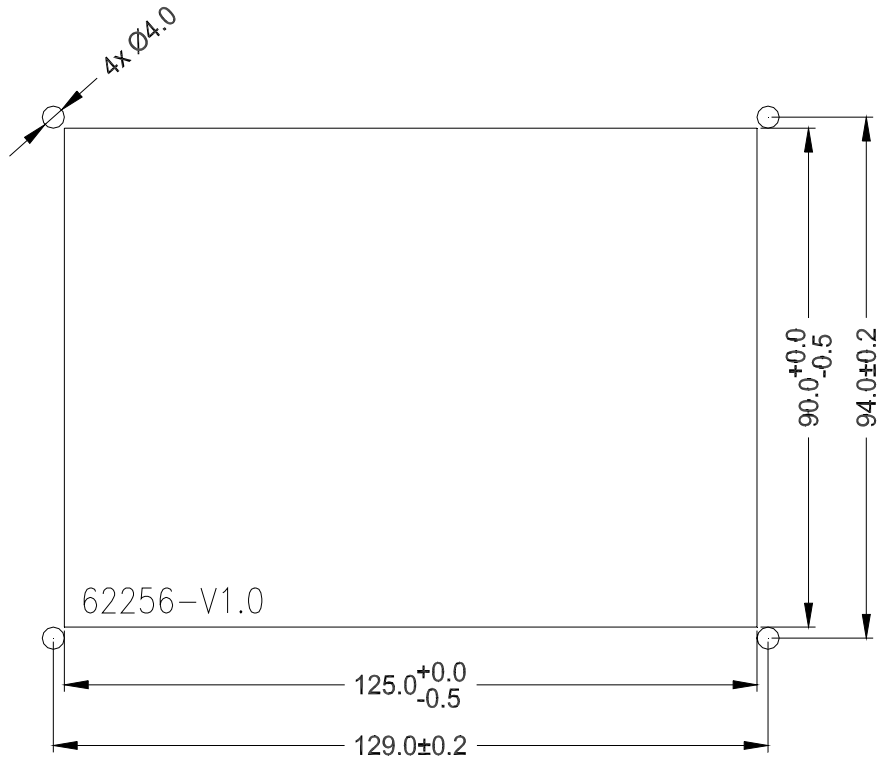

7.4 MECHANICAL DIMENSIONS - FRONTSIDE 3,5" TO 7"

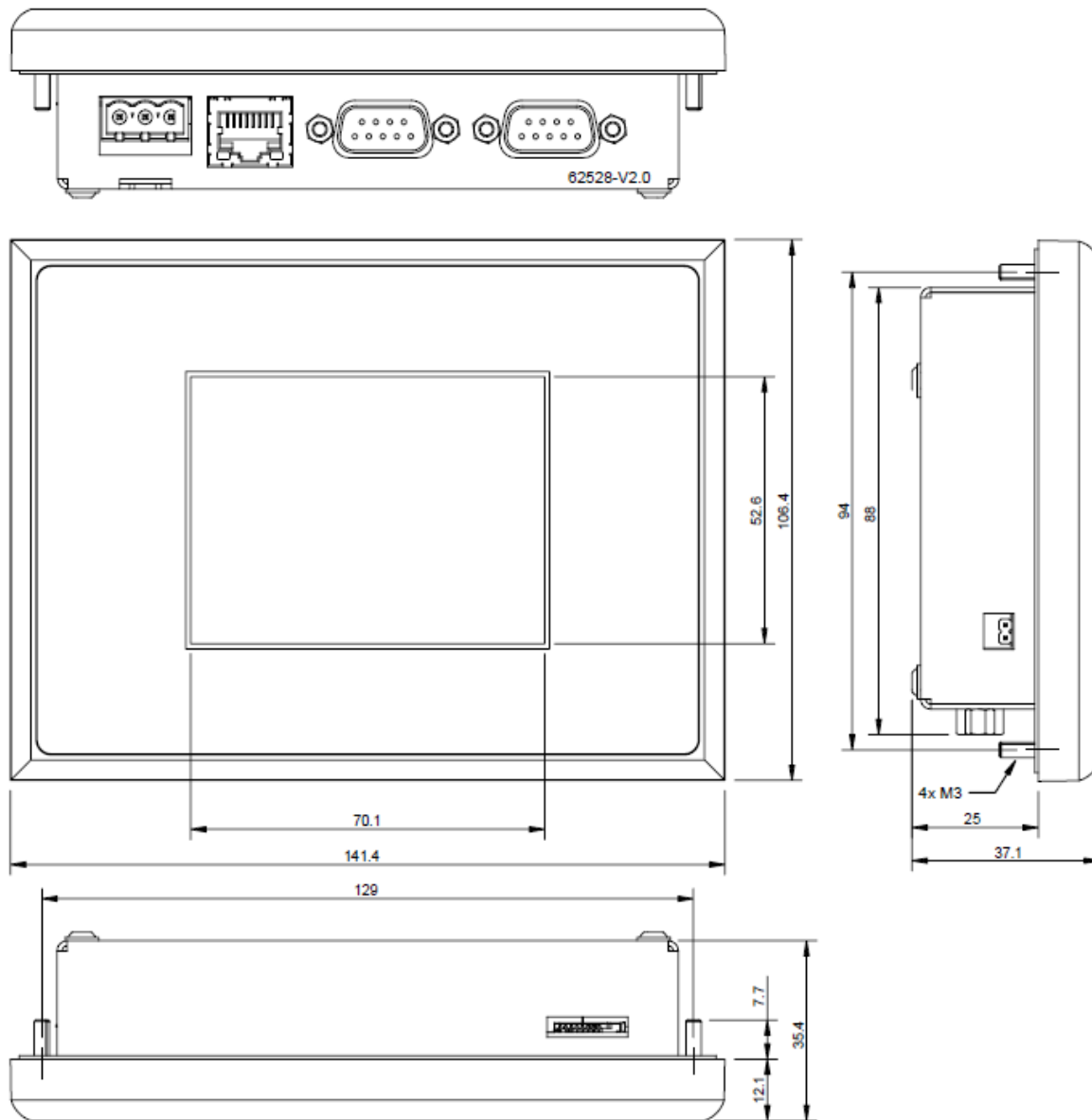

Dimensions – 3,5"

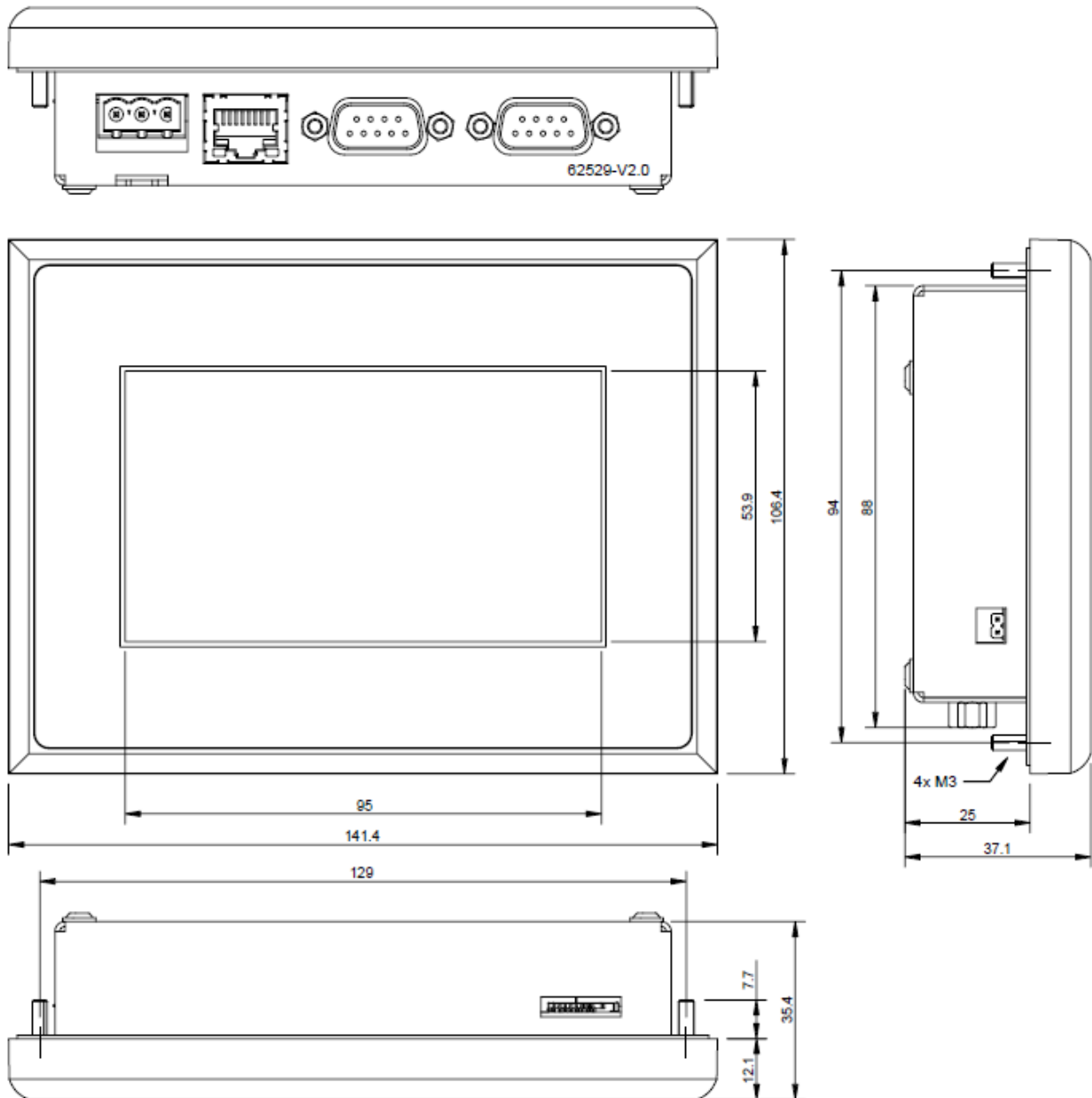

Dimensions – 4,3" IR

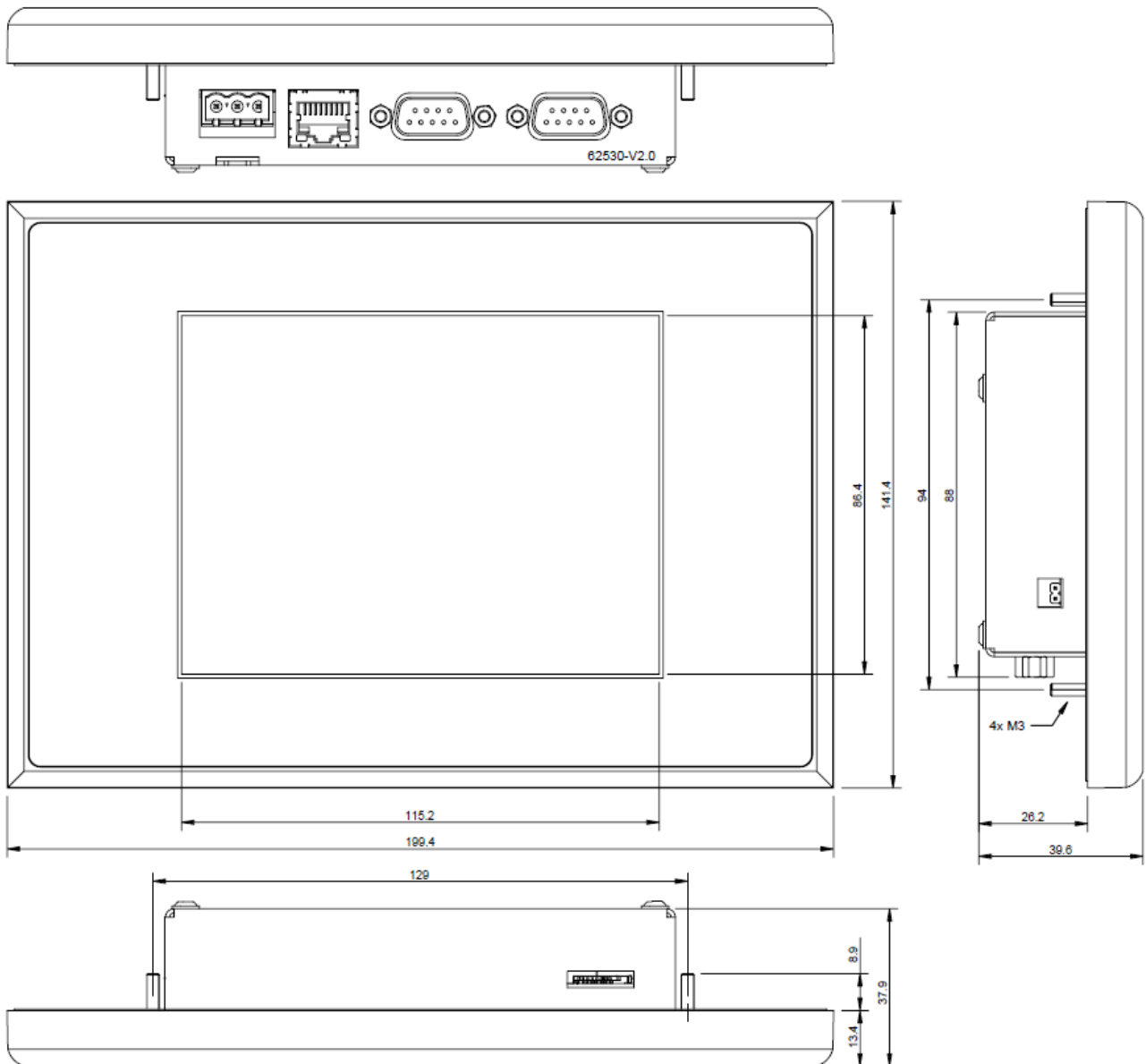

Dimensions – 5,7“

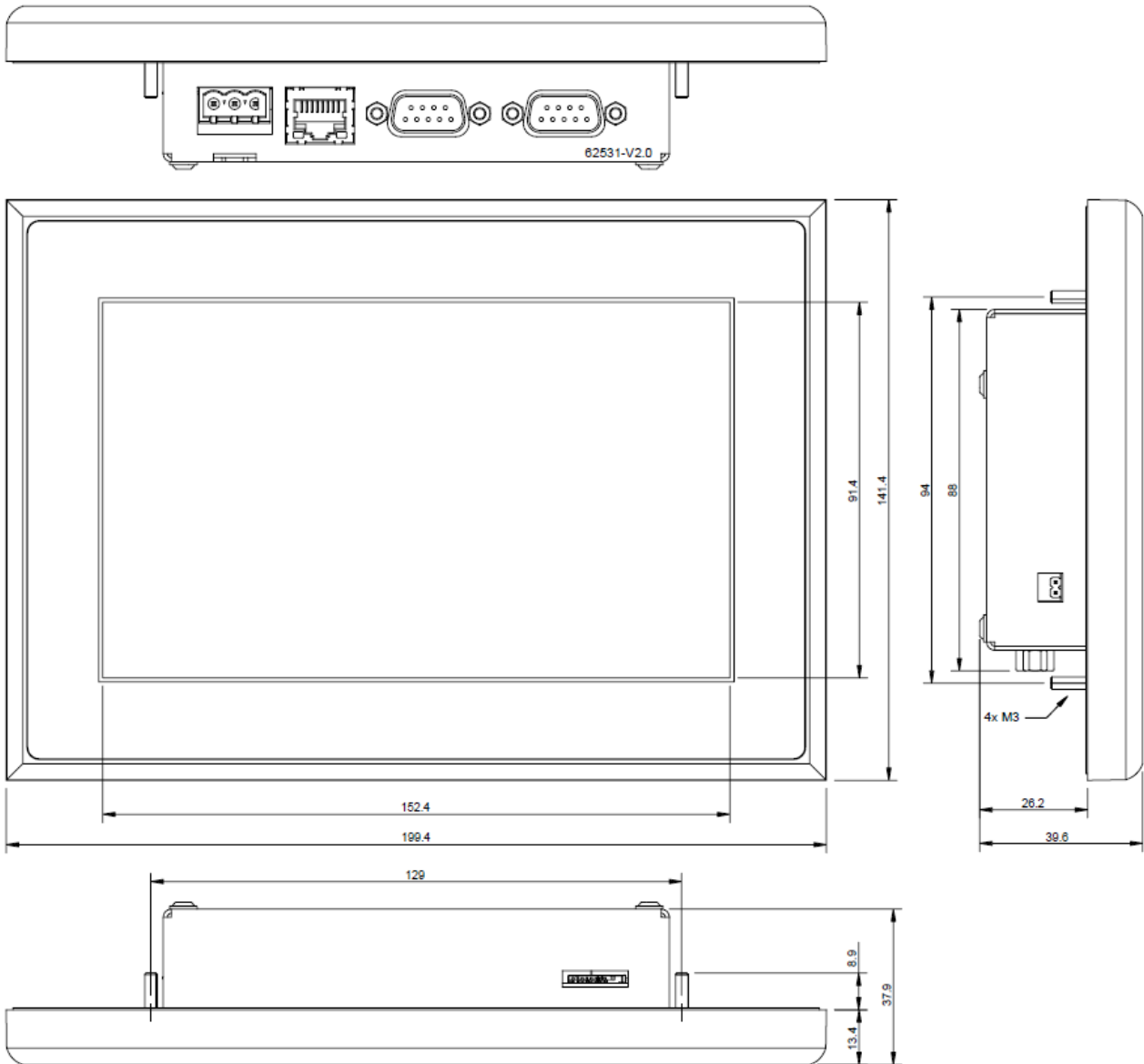

Dimensions - 7"

8 Notes on the touch-screen

8.1 BASIC TOUCH-SCREEN FUNCTION

Devices with resistive touch-screen

The resistive touch-screen operates on an analog principle. Pressing the touch-screen at any point results in an electrical resistance which is measured and will be calculated into a position by the touch controller. This initiates an operation if a touch activated screen element was touched (e.g. a button).

Because of this function principle the resistive touch-screen has to be calibrated. The first calibration is already done when delivered. A recalibration of the touch-screen is necessary when the touch position is different to the screen, e.g. because of ageing, temperature, etc.

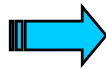

For an optimal operation of the resistive touch-screen it is recommended to use a touch-pen for the calibration.

(s.a. manual system description WindowsCE)

9 Backlight, contrast

9.1 CONTRAST

The SmartPanel series are delivered with TFT displays. This displays require no contrast settings (only necessary for passive LCD displays).

9.2 BACKLIGHT

The backlight can be selected in the application program.

9.3 DIAGNOSTICS

The following optical and acoustic diagnostic options are available:

Symptom	Possible cause and solution
Device does not start, screen dark or error messages during startup	- Check power supply/fuse faulty
Date/time incorrect	- device was not powered for at least 1 week → setup RTC
Touch-screen not functioning	- Hardware faulty or touch not calibrated → recalibrate touchscreen
Ethernet connection faulty	- Incorrect Ethernet cable fitted (crossover/direct). → The LINK LED is lit when the connection is correct → The ACT LED is lit (flashing during transfer) with a correct data transfer - Incorrect/invalid IP address set

10 Maintenance and repair

Cleaning of resistive touch-screen

Do not expose the front of the device to solvents which may corrode and loosen the plastic membrane (material: Polyester). Ensure that the surface is not scratched or scoured, especially when removing hard deposits and abrasive dust.

Cleaning should only be carried out with the device switched off! This will ensure that any touching of the screen will not accidentally initiate functions.



Please use a soft cloth to ensure that the surface is not scratched or scoured. Do not use solvents.

Repairs

Repairs to the SmartPanels should only be carried out by the manufacturer. (manufacturer address → Section 13)

No liability is accepted for any modifications made to the device that are not described in this document.

Transport

Only the original packaging must be used for transporting the device. The climatic conditions (→ Section 11) has to be observed.

Storage

The device has to be stored under the conditions specified in Section 11.

It is recommended to store the device at room temperature.

11 Technical data

Display	Technology	3,5", 4,3", 5,7", 7" TFT LCD		
	Resolution	3,5"	QVGA	320 x 240
		4,3"	WQVGA	480 x 272
		5,7"	VGA	640 x 480
		7"	WVGA	800 x 480
	Display area	3,5"	70 x 53 mm	
		4,3"	95 x 53 mm	
5,7"		115 x 86 mm		
7"		152 x 91 mm		
Backlight	LED, dimmable via software			
	3,5"	40000h, contrast 450:1, brightness 350cd/m2		
	4,3"	40000h, contrast 300:1, brightness 350cd/m2		
	5,7"	40000h, contrast 350:1, brightness 400cd/m2		
Front plate	7"	40000h, contrast 350:1, brightness: 350cd/m2		
	Resistive touch-screen: Polyester/glass laminate			
Operation	Type	Resistive touch-screen, keyboard, mouse		
	Resolution	12 Bit analog (0-4096) for all display sizes		
	<i>Resistive touch-screen</i>			
	Keyboard Mouse	Via USB		
Ambient conditions	Operating climate	Class 3K3	EN50178 (advanced/reduced)	
		0..60°C vertical installation 10...90% rel. air humidity, non-condensing		
	Storage climate	Class 1K4	EN50178 (reduced)	
		-20...70°C, 10...90% rel. air humidity, non-condensing		
	Transport climate	Class 2K3	EN50178 (reduced)	
		-20...70°C, 10...90% rel. air humidity, non-condensing		
Vibration	<60Hz: 3.5mm	EN60068-2-6		
	>60Hz : 1g	EN60068-2-6		
Shock	15g / 11ms	EN60068-2-27		
EMC	EMC interference immunity	Industrial	EN 61000-6-2	
		4kV / 8 kV	EN 61000-4-2	
		10V/m	EN 61000-4-3	
		2kV	EN 61000-4-4	
		0.5kV / 0.5kV	EN 61000-4-5	
		10Vrms	EN 61000-4-6	
Emission	Residential	EN 61000-6-3		
Degree of protection	Front	IP 65 (NEMA 12), after EN 60068-2-68 → note section 7.1		
	Rear	IP20		

Technical data (continue)

Weight		3,5"	approx. 0,45kg
		4,3"	approx. 0,5kg
		5,7"	approx. 0,65kg
		7"	approx. 0,7kg
Dimensions	B x H x T	3,5/4,3" 5,7/7"	142 x 107 x 36(25)mm 200 x 142 x 38(27)mm
	Cutout		125 x 90 mm (mounting holes: 129x94 Ø4mm) → see mounting instructions!
System supply	Rated voltage		24 VDC SELV, safety extra low voltage, protection class III
	Voltage range		24 VDC to DIN 19240 10...28.8 VDC effective, absolute value with ripple 8.5...30.2 VDC 35.0 VDC for a duration of < 100ms
	Voltage dips		EN61000-6-2, up to 5s (→ 5.3)
	Protection against reverse polarity		Yes (→ 5.2)
	Fuse protection		Yes
	Potential isolation		No
	Current consumption (Idle, without USB-load)	3,5" 4,3" 5,7" 7"	4W 4W 5W 6W
CPU	Type		ARM9 iMX25 400MHz
Memory	Type		64MB soldered
Realtime clock	Counters		Seconds, minutes, hour, day, month, year
	Leap year change		Automatic
	DST change		Manual via the software
	Backup		Capacitor backup for approx. 1 week
Fuse protection	device internal		1 A Fast
	Breaking capacity		tbd
Communication-Interfaces	Ethernet		1x 10/100Mbps RJ45 (→ 5.7)
	USB 1-2	2 x 2.0	USB-connector (→ Kap.5.8)
	COM1	RS232/485/422	D-Sub 9 Pol male (→ Kap. 5.9)
	CAN	CAN, not isolated	CiA, D-Sub 9 Pol male (→ Kap. 5.10)
	Temp.connector		Connector for KTY10-6 (= KTY81-210) sensor (→ Kap.Fehler! Verweisquelle konnte nicht gefunden werden.)
Micro-SDCARD Slot	Micro-SDCARD		Exchangeable storage device

12 Disposal

SmartPanel devices that are no longer used must be disposed of properly or returned to the manufacturer for disposal. (manufacturer's address → Section 13)

Materials:

Housing:	Galvanized sheet steel
Front frame:	Plastic
Printed-circuit board:	1. quality
Front:	Polyester/glass laminate

13 EU Conformity and Standards

The SmartPanel meets the requirements specified by the EU Council Directives for harmonizing the regulations of EU member states relating to electromagnetic compatibility (**89/336/EEC**).

The generic standards below were used to assess the electromagnetic compatibility of the SmartPanel:

EN 61000-6-3 (Emission)

EN 61000-6-2 (Immunity)



The following standard was used to assess the functionality of the SmartPanel:

EN 61131-2

The following standard was used to assess the electrical safety of the SmartPanel:

EN 60950 und EN 50178

Manufacturer:	Grossenbacher Systeme AG
Manufacturer address:	Spinnereistrasse 10 CH-9008 St.Gallen Switzerland

14 Revision history

Revision	Date / Signed	Modifications
1.0	04-11 / Fis	First version
2.0	05-11 / Fis	P.19 RS485 Signal A/B changed
3.0	10-11 / Fis	P.19 COM1 discription changed

Manufacturer address:

Grossenbacher Systeme AG
Spinnereistrasse 10
CH-9008 St.Gallen
Switzerland

Tel : +41 (0)71 243 29 29
Fax : +41 (0)71 243 29 28
Email : info@gesys.ch
Homepage : www.gesys.ch

Branch Germany:

Grossenbacher Systeme GmbH
Ruhrstrasse 15
D-63452 Hanau
Germany

Tel : +49 (0)6181 6751 999
Fax : +49 (0)6181 6751 998
Email : sales.de@gesys.ch
Homepage : www.gesys.ch

15 Alphabetical index

A	
Accessories	12
Additional documentation	9
Ambient conditions	37
B	
Backlight	33
Backlight, contrast	33
Basic touch-screen function	31
C	
CAN	15
CAN connector	20
CAN interface	19
COM1	13, 15
Commissioning	15
communication-interfaces	13
Connecting the power supply	15
Contents	5
Contrast	33
Copyright	2
D	
Danger warnings	7
Degree of protection	37
Device Versions	11
Diagnostics	33
Dimensions	38
Display	13, 37
Disposal	39
E	
Ethernet	13, 15, 18
EU Conformity and Standards	41
Exchangeable memory	13
Explanation of symbols	7
F	
Features	13
Front panel cutout	25
Fuse	16
Fuse protection	38
I	
Inserting /Removing the Micro-SDCARD	22
Introduction	9
K	
Keyboard	13
M	
Maintenance and repair	35
Manufacturer	41
Manufacturer address	43
mass storage	13
Mechanical dimensions - Frontside	26
Micro-SDCARD	15
Minimum clearance	23
Mounting in the front panel - General	23
Mouse	13
N	
Notes on the touch-screen	31
O	
Operation	23
Overview of connections	15
P	
Power Fail and UPS	16
Preparing the shield connections	17
Proper use	3
R	
Realtime clock	13, 38
Repairs	35
Revision history	43
S	
Safety instructions for the user	4
Scope of delivery	11
Setup of RTC	16
Startup / Shutdown behaviour	23
Storage	35
System description CoDeSys Soft-PLC	9
System description WindowsCE	9
System supply	38
T	
Technical data	37
Temp.sensor connector	22
Transport	35
U	
USB	13, 15, 18
W	
Warnings	7
Weight	38

